

VENTILATED SYSTEM Q-VENT FOR MOUNTING CERAMIC TILES AGROB BUCHTAL

MAIN SUPPORTING JOINT PROFILE

WEIGHT 1168.00 g/m
A = 4.33 cm²

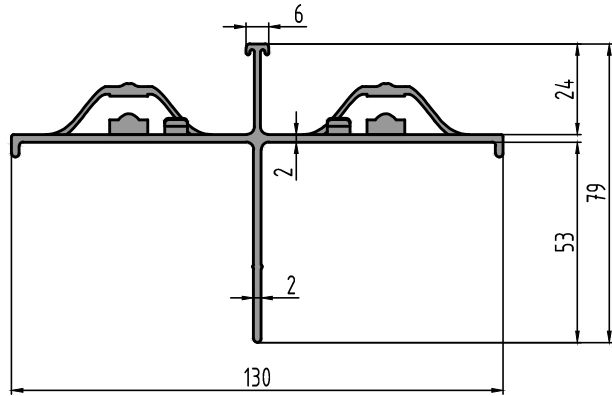

MAIN SUPPORTING T PROFILE

WEIGHT 1034.27 g/m
A = 3.83 cm²

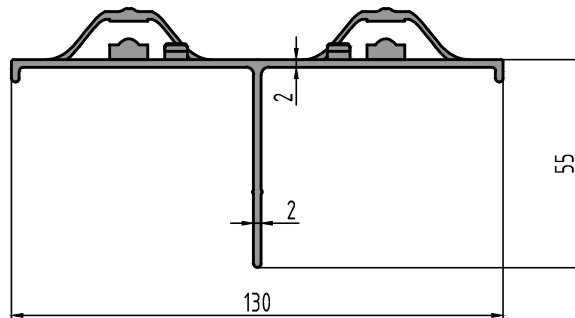

MAIN SUPPORTING CORNER PROFILE
ONE-SIDE PUNCHED

WEIGHT 666.00 g/m
A = 2.47 cm²

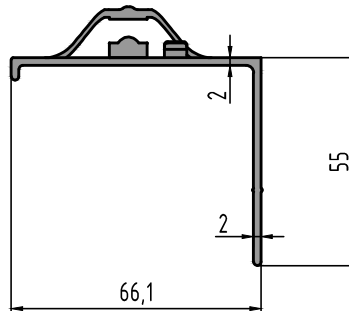

MAIN SUPPORTING CORNER PROFILE
TWO-SIDE PUNCHED

WEIGHT 700.26 g/m
A = 2.59 cm²

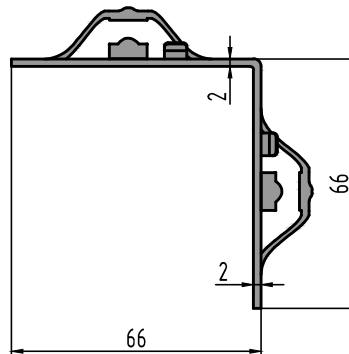

DRAWING TITLE: K20 MAIN PROFILES

DRAWING No: 103.200.1

VENTILATED SYSTEM Q-VENT

DESIGNER: TATYANA IVANOVA

REFERENCE:

PAGE: 1/1

REV 00

SCALE: 1:2.5

DATE: 05.09.2011

Q-VENT

Bulgaria, Sofia
18 Kliment Ohridski blvd
floor 7, office 708

+359 888 44 00 85
office@q-vent.eu
q-vent.eu

The engineering design of this project is an intellectual property of Q-VENT. Coping and distributing any parts of the product is a violation of the copyright law.

VENTILATED SYSTEM Q-VENT FOR MOUNTING CERAMIC TILES AGROB BUCHTAL

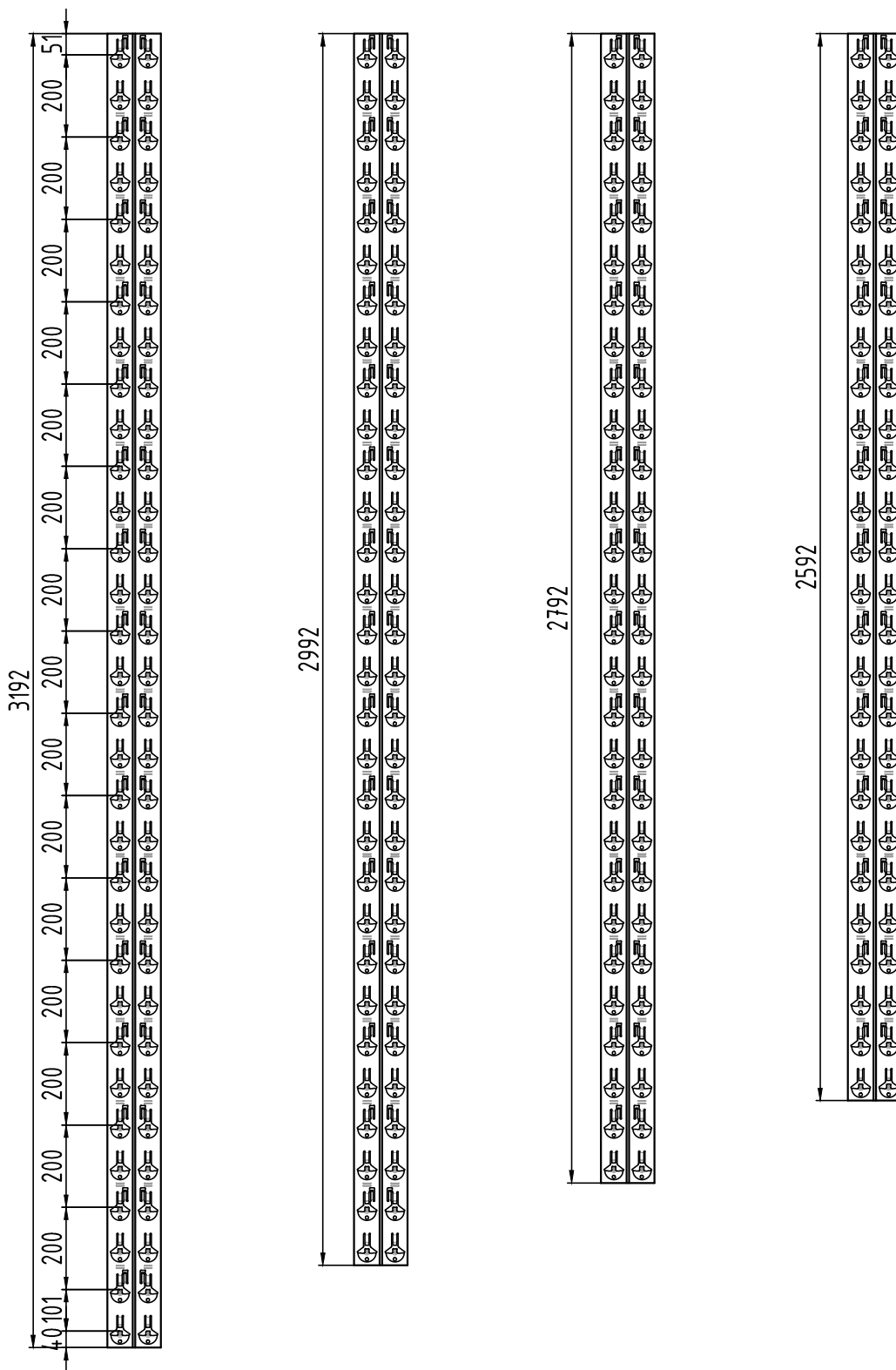

DRAWING TITLE: K20 MAIN PROFILES MODULE 200

DRAWING No: 103.200.2

PAGE: 1/1

VENTILATED SYSTEM Q-VENT

REV 00

DESIGNER: TATYANA IVANOVA

SCALE: 1:2.5

REFERENCE:

DATE: 05.09.2011

Q-VENT

Bulgaria, Sofia
18 Kliment Ohridski blvd
floor 7, office 708

+359 888 44 00 85
office@q-vent.eu
q-vent.eu

The engineering design of this project is an intellectual property of Q-VENT. Coping and distributing any parts of the product is a violation of the copyright law.

VENTILATED SYSTEM Q-VENT FOR MOUNTING CERAMIC TILES AGROB BUCHTAL

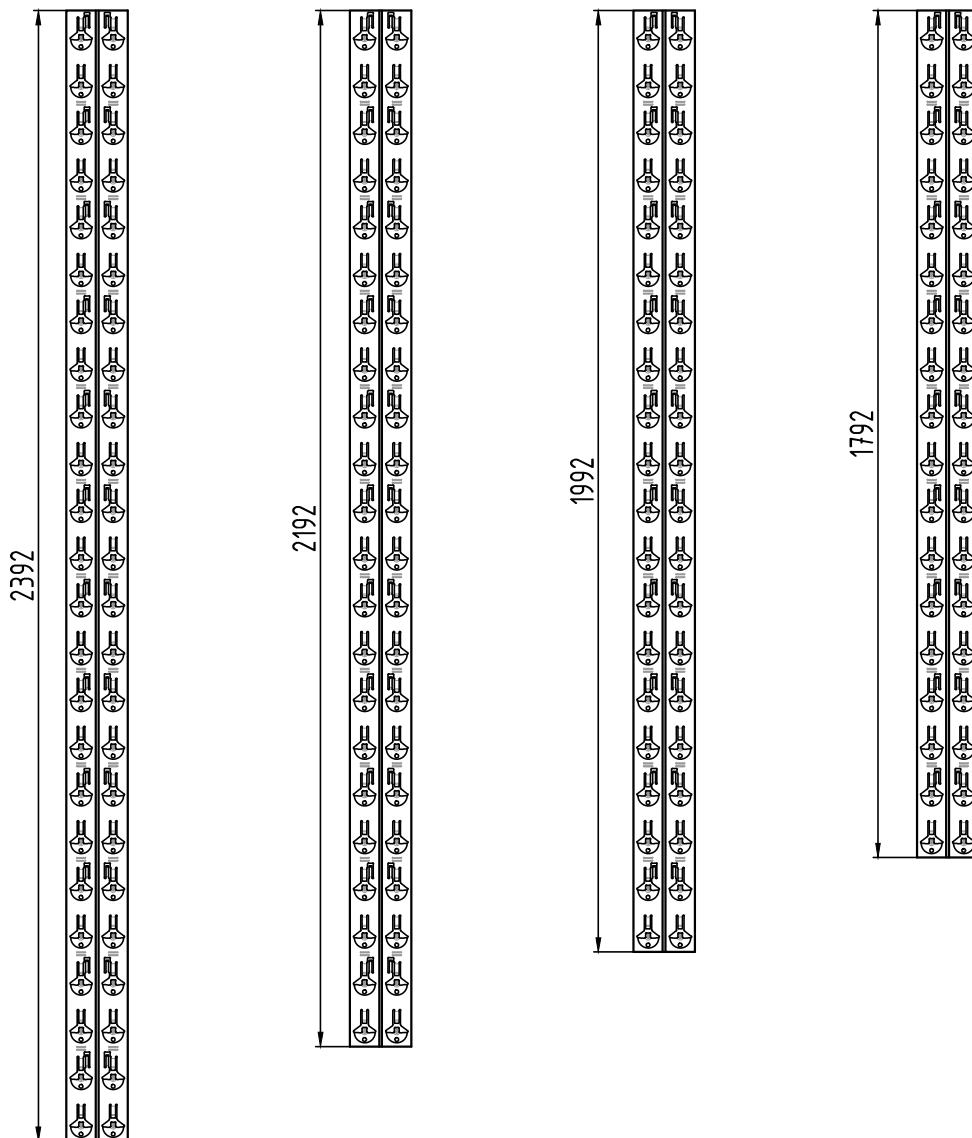

DRAWING TITLE: K20 MAIN PROFILES MODULE 200

DRAWING No: 103.200.3

PAGE: 1/1

VENTILATED SYSTEM Q-VENT

REV 00

DESIGNER: TATYANA IVANOVA

SCALE: 1:2.5

REFERENCE:

DATE: 05.09.2011

Q-VENT

Bulgaria, Sofia
18 Kliment Ohridski blvd
floor 7, office 708

+359 888 44 00 85
office@q-vent.eu
q-vent.eu

The engineering design of this project is an intellectual property of Q-VENT. Coping and distributing any parts of the product is a violation of the copyright law.

VENTILATED SYSTEM Q-VENT FOR MOUNTING CERAMIC TILES AGROB BUCHTAL

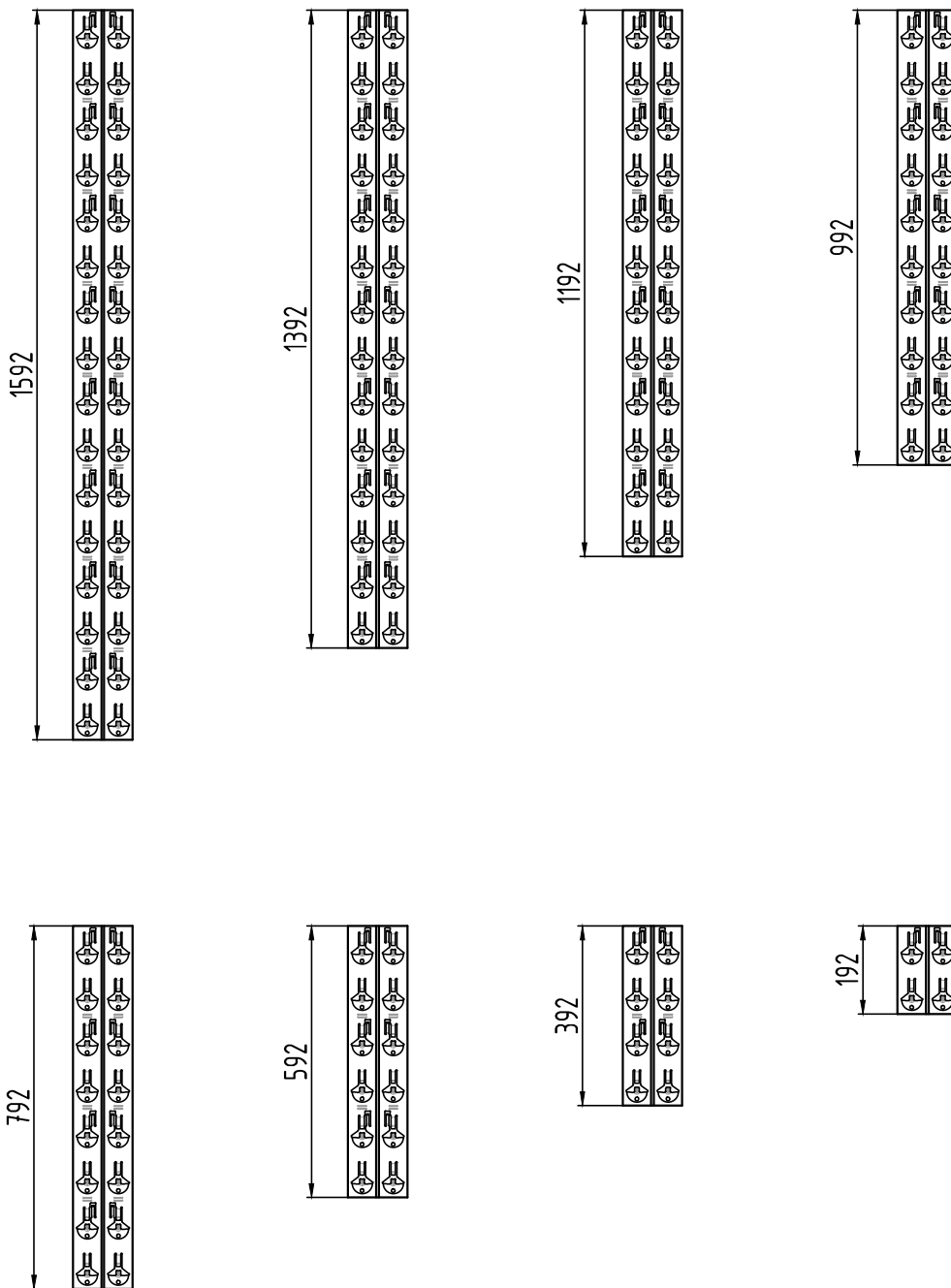

DRAWING TITLE: K20 MAIN PROFILES MODULE 200

DRAWING No: 103.200.4

PAGE: 1/1

VENTILATED SYSTEM Q-VENT

REV 00

DESIGNER: TATYANA IVANOVA

SCALE: 1:2.5

REFERENCE:

DATE: 05.09.2011

Q-VENT

Bulgaria, Sofia
18 Kliment Ohridski blvd
floor 7, office 708

+359 888 44 00 85
office@q-vent.eu
q-vent.eu

The engineering design of this project is an intellectual property of Q-VENT. Coping and distributing any parts of the product is a violation of the copyright law.